

## Embrague VIROFLEX® tipo EMZ-B

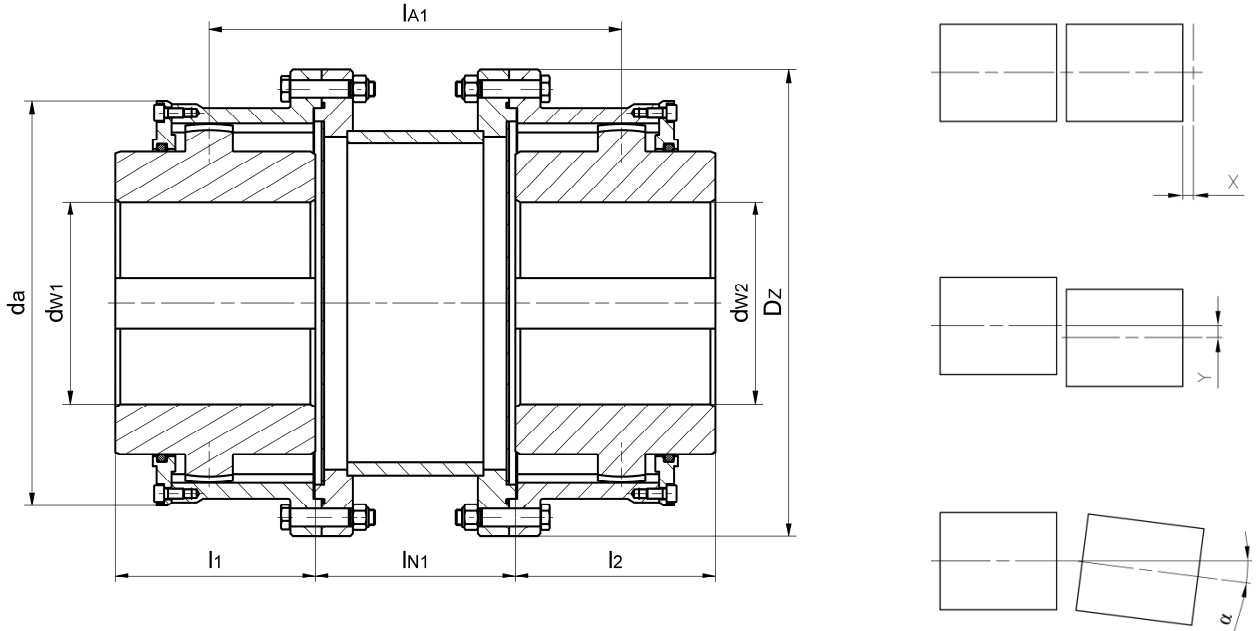

Tamaño y tipo de embrague	d <sub>w1</sub> , d <sub>w2</sub> (H7)	l <sub>1</sub> , l <sub>2</sub> * nomin.	d <sub>a</sub>	D <sub>z</sub>	l <sub>A1</sub> * nomin.	l <sub>N1</sub> * nomin.	diferenciales máx.***			velocidad rev. máx.	momento de inercia**	memoen to nomin.	masa**
							x	y**	α				
-	mm								deg.	l/min	kg*m <sup>2</sup>	Nm	kg
EMZ-B01	45	50	104	140	175	120	1,0	1,7	1,00	8800	0,017	1350	7,73
EMZ-B02	55	60	125	155	180	120	1,5	1,8		7800	0,030	2600	10,54
EMZ-B03	65	75	142	180	210	130	2,0	2,1		6500	0,071	4300	18,13
EMZ-B04	80	90	162	215	233	133	2,0	2,3		6000	0,140	7000	25,65
EMZ-B05	95	100	191	240	253	143	2,0	2,5		5000	0,275	12000	37,96
EMZ-B06	110	110	216	265	260	140	3,0	2,6		4500	0,450	19000	52,10
EMZ-B07	125	125	247	305	280	150	3,0	2,7		3800	0,840	28000	73,20
EMZ-B08	145	145	279	345	310	160	4,0	3,0		3300	1,658	40000	112,50
EMZ-B09	160	160	321	370	330	160	4,0	3,5		3000	2,474	55000	141,70
EMZ-B10	180	180	349	420	380	180	5,0	4,0		2700	4,421	70000	194,62
EMZ-B11	200	200	394	460	420	200	5,0	4,5		2300	7,249	100000	261,00
EMZ-B12	220	220	430	500	460	200	5,0	5,0		2000	10,487	130000	322,90

\* A petición, fabricamos embragues con otras longitudes distintas a las normales.

\*\* Masa y momento de inercia determinados para el orificio más grande.

\*\*\* Durante el montaje mantener el 15% de los valores máximos.

### EMM Industry inż. Marcin Filipek

Telf.: +48 12 2589187  
 Fax: +48 12 2828051  
 e-mail: emm@emm.com.pl  
 www.emm.com.pl

ul. 3 Maja 39  
 32-551 Babice  
 NIP 628-137-05-93  
 REGON 852697180

Wydział Produkcyjny Alwernia  
 ul. Karola Olszewskiego 25  
 Budynek B-109  
 32-566 Alwernia

Bank BPH S.A. Kraków Al. Pokoju 1  
 SWIFT BIC: BPHKPLPK  
 Número de cuentas:  
 PLN: 92-10600076-0000326000228056  
 USD: 52-10600076-0000330000651075  
 GBP: 70-10600076-0000330000739991