

Coupling VIROFLEX® EMZ-A type

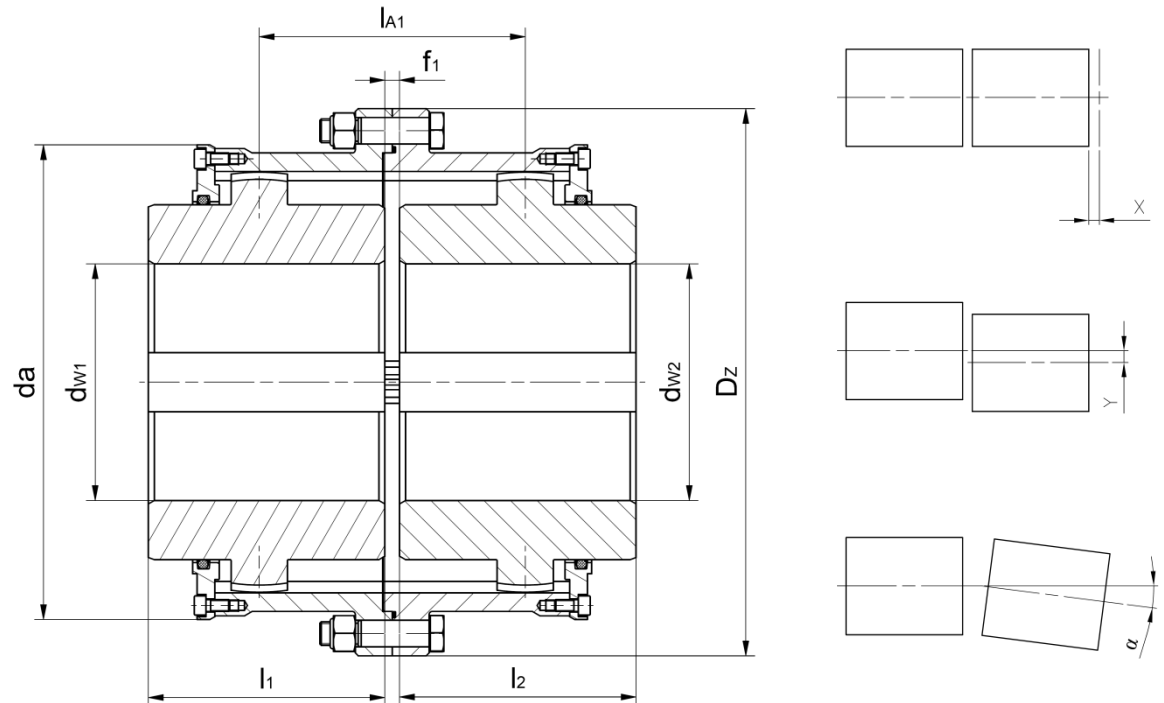

Size and coupling type	d _{w1} , d _{w2} (H7)	l ₁ , l ₂ * nomin.	d _a	D _Z	l _{A1} * nomin.	f ₁	Max deviation***			Max rotational speed	Moment of inertia**	Rated moment	Weight**
							x	y	α				
-	mm								deg.	1/min	kg*m ²	Nm	kg
EMZ-A01	45	50	104	140	55	5	1,0	0,5	1,00	9000	0,010	1350	4,97
EMZ-A02	55	60	125	155	65		1,5	0,6		8000	0,019	2600	7,30
EMZ-A03	65	75	142	180	85		2,0	0,8		7000	0,044	4300	12,24
EMZ-A04	80	90	162	215	108	8	2,0	1,0		6200	0,088	7000	17,60
EMZ-A05	95	100	191	240	118		2,0	1,0		5400	0,181	12000	27,60
EMZ-A06	110	110	216	265	128	10	3,0	1,2		4700	0,312	19000	39,12
EMZ-A07	125	125	247	305	140		3,0	1,2		4000	0,580	28000	57,48
EMZ-A08	145	145	279	345	160		4,0	1,5		3500	1,135	40000	85,50
EMZ-A09	160	160	321	370	180		4,0	1,5		3200	1,847	55000	114,00
EMZ-A10	180	180	349	420	215	15	5,0	2,0		2800	3,131	70000	153,00
EMZ-A11	200	200	394	460	235		5,0	2,2		2500	5,183	100000	206,60
EMZ-A12	220	220	430	500	275		5,0	2,5		2200	7,876	130000	267,00

* Upon request we can manufacture couplings in custom sizes

** Weight and moment of inertia are shown for the biggest opening

*** During installation keep 15% of max value

EMM Industry inż. Marcin Filipek

Tel.: +48 12 2589187
 Fax: +48 12 2828051
 e-mail: emm@emm.com.pl
 www.emm.com.pl

ul. 3 Maja 39
 32-551 Babice
 NIP 628-137-05-93
 REGON 852697180

Alwernia manufacturing unit
 ul. Karola Olszewskiego 25
 Building B-109
 32-566 Alwernia

Bank BPH S.A. Kraków Al. Pokoju 1
 SWIFT BIC: BPHKPLPK
 Account no:
 PLN: 92-10600076-0000326000228056
 USD: 52-10600076-0000330000651075
 GBP: 70-10600076-0000330000739991