

## Heavy Duty Slurry Valve **MAGMAGATE®** MAG-R type

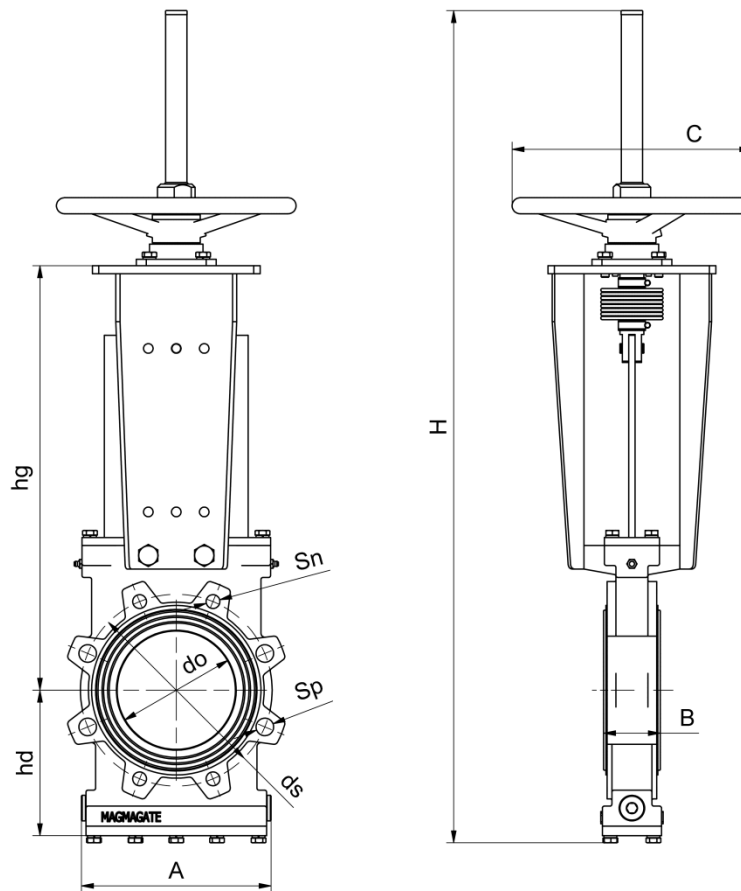

Type	Size	do	B	ds	H	hd	hg	A	C	Sp	Sn	Weight
-	-	mm										kg
MAG-R-01	DN50	49	47	125	583	113	290	115	200	-	4xM16	10,00
MAG-R-02	DN65	63	57	145	672	123	340	134	250	4x18	4xM16	16,80
MAG-R-03	DN80	78	57	160	727	130	370	155	250	4x18	4xM16	19,00
MAG-R-04	DN100	98	57	180	792	135	401	175	250	4x18	4xM16	21,00
MAG-R-05	DN125	123	64	210	953	160	490	210	300	4x18	4xM16	35,50
MAG-R-06	DN150	148	71	240	1041	182	531	238	300	4x22	4xM20	41,50
MAG-R-07	DN200	198	76	295	1305	217	688	297	350	4x22	8xM20	73,80
MAG-R-08	DN250	248	82	350	1475	247	768	348	400	4x22	8xM20	90,50
MAG-R-09	DN300	298	89	400	1646	272	855	403	500	4x22	8xM20	109,00
MAG-R-10	DN350	330	93	460	1863	312	970	452	600	4x22	12xM20	170,00
MAG-R-11	DN400	380	103	515	2032	342	1053	507	600	4x26	12xM24	195,00

**EMM Industry inż. Marcin Filipek**

Tel.: +48 12 2589187  
 Fax: +48 12 2828051  
 e-mail: emm@emm.com.pl  
 www.emm.com.pl

ul. 3 Maja 39  
 32-551 Babice  
 NIP 628-137-05-93  
 REGON 852697180

Alwernia manufacturing unit  
 ul. Karola Olszewskiego 25  
 Building B-109  
 32-566 Alwernia

Bank BPH S.A. Kraków Al. Pokoju 1  
 SWIFT BIC: BPHKPLPK  
 Account no:  
 PLN: 92-10600076-0000326000228056  
 USD: 52-10600076-0000330000651075  
 GBP: 70-10600076-0000330000739991